

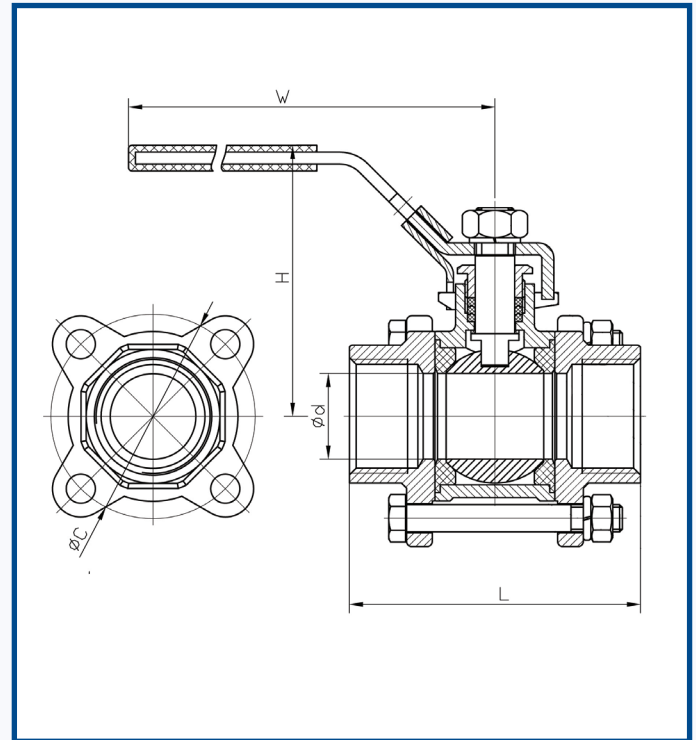

CP301CL



Body:	Carbon Steel ASTM A216
Cap:	Carbon Steel ASTM A216
Ball:	Stainless Steel CF8
Seats:	RPTFE
Stem:	Stainless Steel SS316
Hex Nut:	Stainless Steel SUS304
Thrust Washer:	PTFE
Packing:	PTFE
Gland:	Stainless Steel SUS304
Spring Washer:	Stainless Steel SUS304
Stem Nut:	Stainless Steel SUS304
Locking Device:	Stainless Steel SUS304
Handle:	Stainless Steel SUS304
Plastic Cover:	Plastic
Bolt Washer:	Stainless Steel SUS304
Plastic Cover:	Stainless Steel SUS304

CONNECTIONS
BSP Parallel: ISO 228 (Equivalent to DIN 259)
BSP Taper: ISO 228 (Equivalent to DIN 2999)
NPT: National Pipe Thread (ANSI B1.20.1)
Socket Weld
Butt Weld: Schedule-40

SIZE	1/4"	3/8"	1/2"	3/4"	1"	1 1/4"	1 1/2"	2"	2 1/2"	3"	4"	5"
d (mm)	11.6	12.7	15.0	20.0	25.0	32.0	38.0	50.0				
L (mm)	58.0	58.0	63.0	73.0	85.0	96.0	114.0	134.0				
H (mm)	52.0	54.0	62.0	66.0	77.0	80.0	91.0	98.0				
W (mm)	102.0	102.0	123.0	123.0	153.0	153.0	183.0	183.0				
C (mm)	37.5	37.5	45.5	52.5	57.5	71.5	79.0	97.0				
Rating	PN63	PN63	PN63	PN63	PN63	PN63	PN63	PN63				
Rating (psi)	1000	1000	1000	1000	1000	1000	1000	1000				
Weight (kg)	0.340	0.317	0.505	0.761	0.984	1.444	2.205	3.325				

Pressure and temperature ratings are minimum and maximum values only and actual performance will be dependant upon application.

All images on this page are for guidance only. E&OE. We reserve the right to amend specifications, prices & products without prior notification